

DBS MANUFACTURING

ENGINEERED FIRSTS | BUILT TO LAST

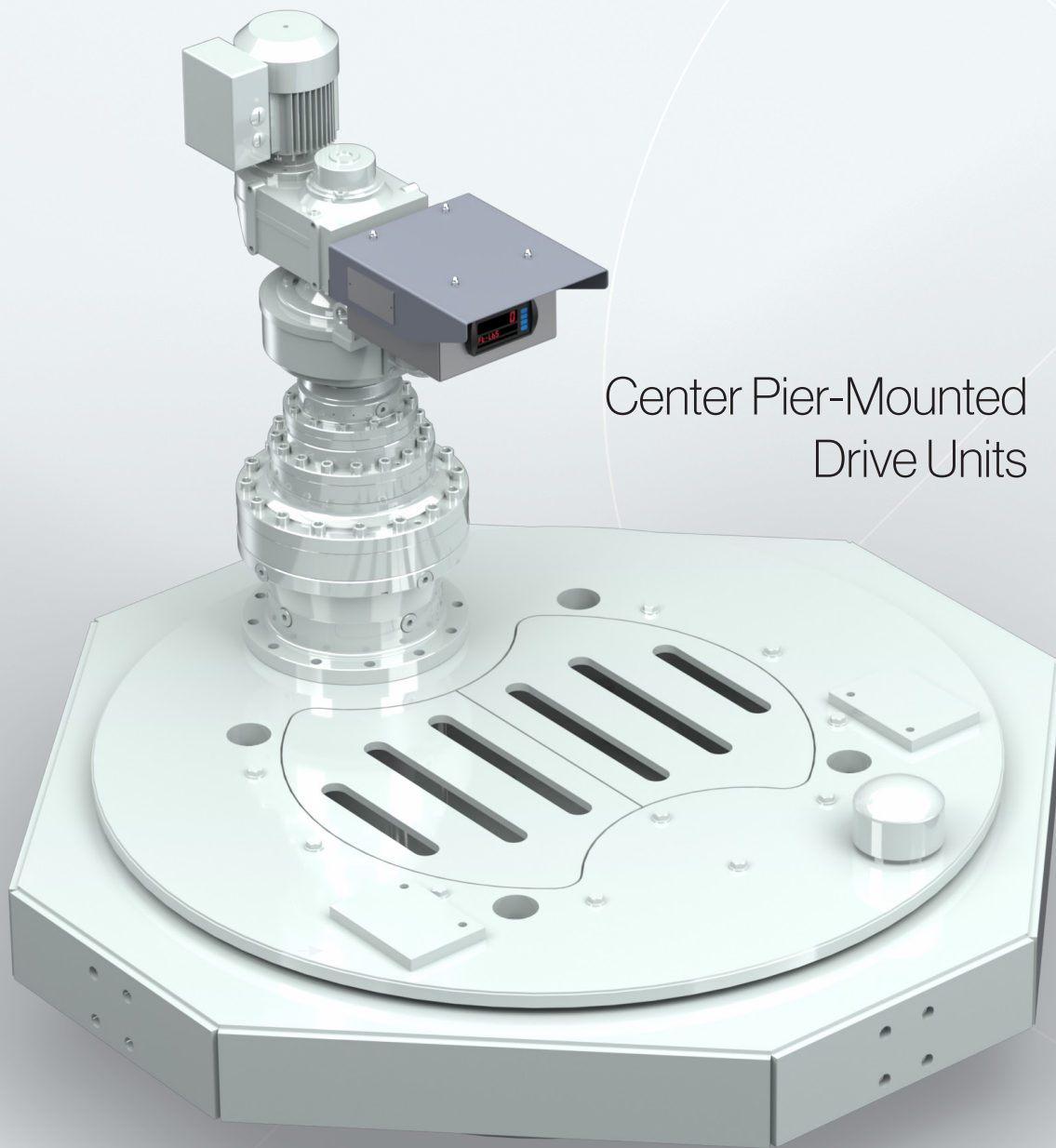

Center Pier-Mounted
Drive Units

Drum Output

DBS MANUFACTURING, INC.

DBS Manufacturing is a successful, privately held business that designs, manufactures, and provides application engineering for products sold to original equipment manufacturers, end users, and municipal and industrial facilities around the world.

Center Pier-Mounted Drive Units

DBS drive units offer a robust low-speed, high-torque gear drive with overload protection. Ideal for industrial, municipal, and mining clarifiers and thickeners, they feature a fully enclosed design supported by a bridge spanning half the tank.

Designed for tanks ranging from 40 to 300 feet (12 to 91 meters) in diameter, the drive units include a forged alloy steel main gear-bearing and pinion designed for a 20-year lifespan. They also feature a precision, four-point-contact main bearing with a 10-year warranty and an accurate torque gauge calibrated in your desired units.

For protection, each unit comes with alarm and cutoff switches in addition to mechanical torque limiting with a shear pin or pressure relief valve. The design also eliminates the lower pinion-bearing, a common failure point, and ensures minimal maintenance with a permanently lubricated intermediate reducer.

In summary, these drive units combine durability, precision, and safety to deliver reliable performance with low maintenance.

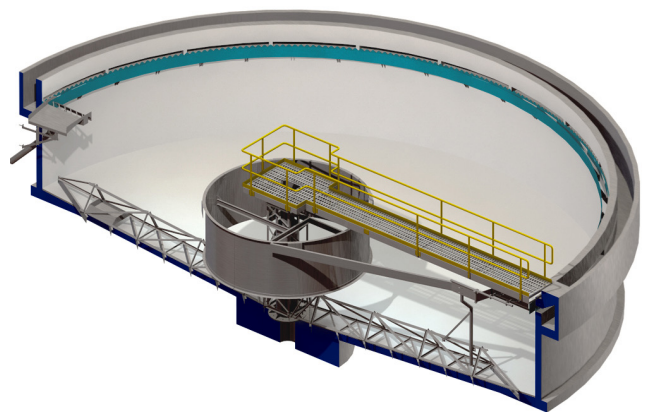

MODEL SELECTION

The D-Series, designed for clarifiers and thickeners with a center column and rake cage, offers a wide range of models to accommodate varying torque requirements.

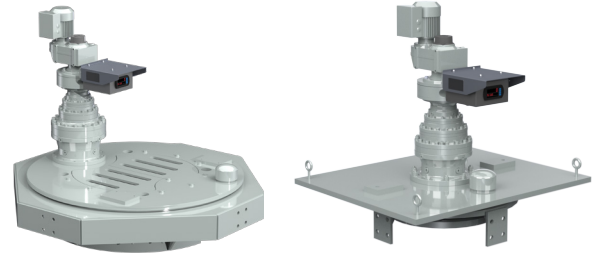

Torque Capacity — Pier-Mounted Drive Units

Model	Continuous		Maximum Overload		Yield	
	ft-lbf	N-m	ft-lbf	N-m	ft-lbf	N-m
DX-A*	3,000	4,100	6,000	8,200	8,100	11,000
DX-B*	6,000	8,200	12,000	16,400	16,200	22,000
D30-A*	16,000	22,000	32,000	44,000	94,000	130,000
D30-B*	27,000	36,500	54,000	73,000	94,000	130,000
D42-B*	35,000	47,500	70,000	95,000	195,000	260,000
D42-C*	50,000	70,000	102,000	138,000	195,000	260,000
D60-C*	65,000	88,000	130,000	176,000	440,000	600,000
D60-D*	125,000	170,000	250,000	340,000	440,000	600,000
D60-E*	250,000	340,000	500,000	680,000	750,000	1,020,000
D80-E*	350,000	475,000	700,000	950,000	950,000	1,290,000
D42-B*2	70,000	95,000	140,000	190,000	390,000	530,000
D42-C*2	100,000	140,000	204,000	280,000	390,000	530,000
D60-C*2	130,000	176,000	260,000	350,000	880,000	1,190,000
D60-D*2	250,000	340,000	500,000	680,000	880,000	1,190,000
D60-E*2	500,000	680,000	1,000,000	1,360,000	1,500,000	2,040,000
D80-E*2	700,000	950,000	1,400,000	1,900,000	1,900,000	2,580,000
D104-G*2	1,250,000	1,695,000	2,500,000	3,390,000	8,840,000	11,990,000
D120-H2	1,750,000	2,370,000	3,500,000	4,750,000	1,650,000	2,240,000

Replace the * with the primary reducer option selected.

Continuous: Torque at which main gear will have a life in excess of 20 years at normal operating speeds.

Maximum Overload: The maximum safe, short term operating torque.

Yield: The structural maximum torque based on the minimum yield strength of the main gear.

DX-SERIES DIMENSIONS

Designed for smaller tanks with a center column and rake cage, the DX-Series drives feature a large precision ball-bearing to carry thrust and moment loads.

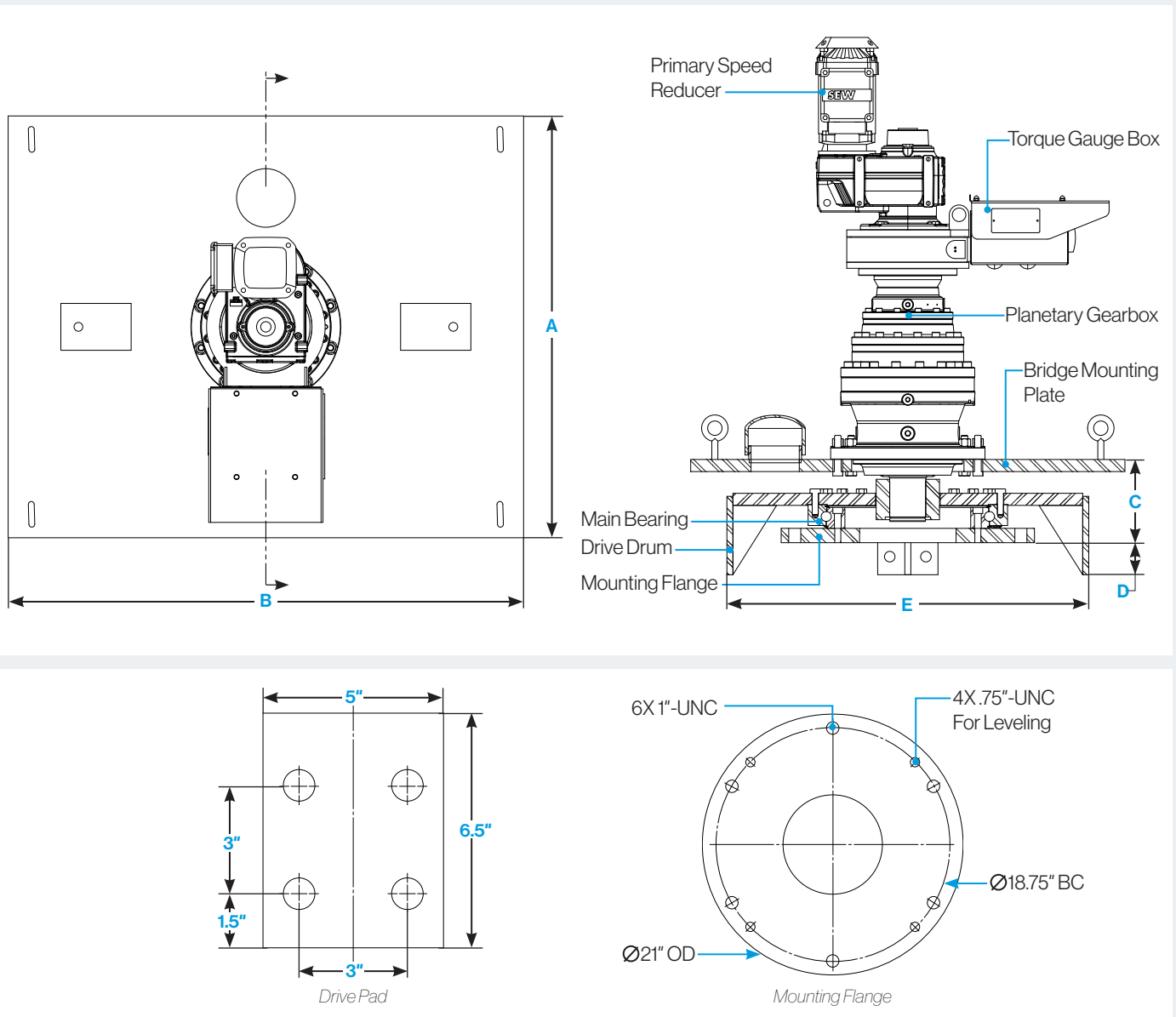

Model	A		B		C		D		E		Weight	
	in	mm	in	mm	in	mm	in	mm	in	mm	lb	kg
DX-A*	36	914	44	1,118	7.9	201	2.7	69	30	762	1,270	576
DX-B*	36	914	44	1,118	8.9	226	2.7	69	30	762	1,400	635

Replace * with the primary reducer option selected.

D-SERIES DIMENSIONS

Designed for large tanks with a center column and rake cage, the D-Series drives feature a large combination internal gear and precision ball-bearing.

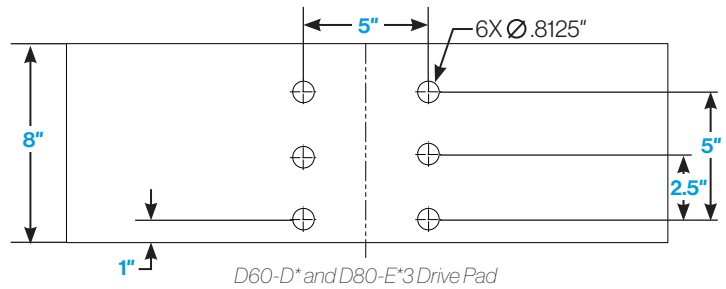
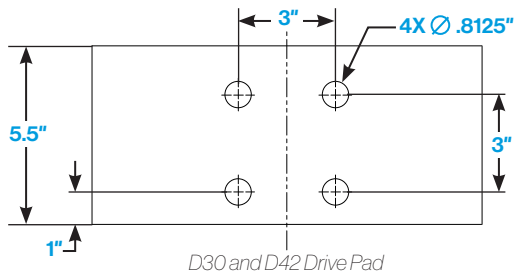
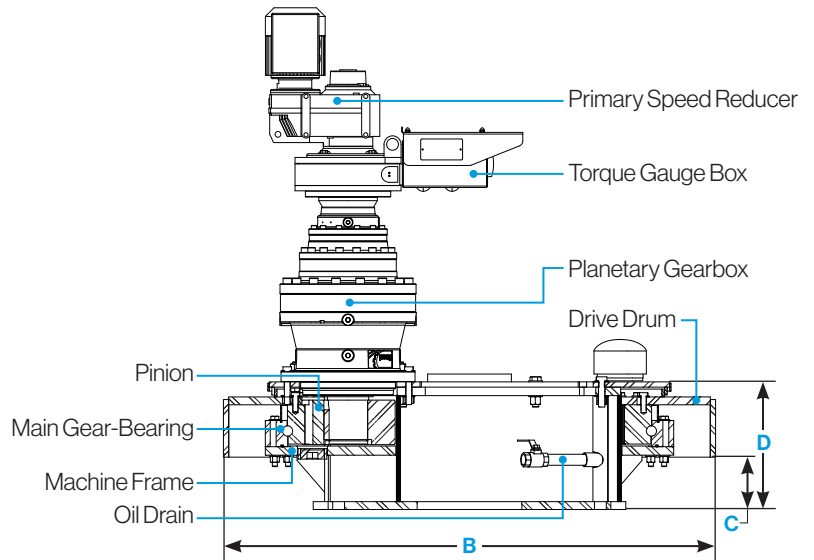
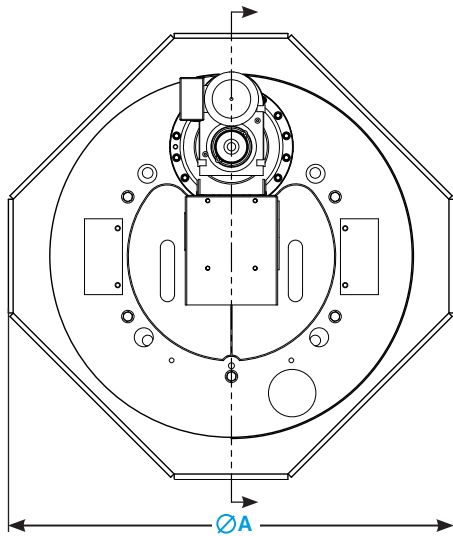

Model	A		B		C		D		Mounting Flange ¹		Weight	
	in	mm	in	mm	in	mm	in	mm	in	mm	lb	kg
D30-A*	40	1,016	47	1,194	4.9	124	12.8	325	32	813	1,750	790
D30-B*	40	1,016	47	1,194	5	127	13.2	325	32	813	1,850	840
D42-B*	50	1,270	60	1,524	5	127	12.9	328	44	1,118	2,500	1,130
D42-C*	57	1,448	60	1,524	5	127	16.6	422	44	1,118	3,050	1,380
D60-C*	74	1,880	80	2,032	6	152	19.4	493	62	1,575	5,600	2,540
D60-D*	72	1,829	80	2,032	6	152	19.7	500	62	1,575	5,850	2,650
D60-E*	75	1,905	74	1,880	9.25	235	21.13	537	57	1,450	8,250	3,740
D80-E*	94.5	2,400	93	2,616	13.75	349	26.6	676	Note ²	Note ²	10,500	4,760

1 Maximum standard outside diameter of mounting flange.
For larger flange sizes, contact factory.
2 Consult factory.

3 Consult factory for D60-E* drive pad dimensions.
Replace * with the primary reducer option selected.

PRIMARY REDUCER OPTIONS

DBS drive units consist of several reducers: primary, secondary, and a final reduction unit that includes a pinion and integral gear-bearing for larger mechanisms. All reducers are directly coupled. A range of primary reduction units is available to meet customer requirements.

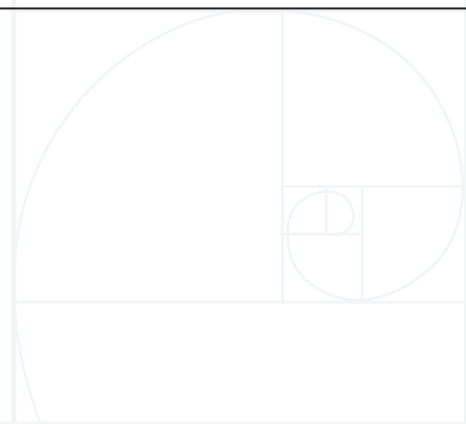

E-TYPE

L-TYPE

F-TYPE

H-TYPE

PRIMARY REDUCER
OPTIONS

One of the reducers *above* will be assembled with one of the drive units *below*.

D-SERIES

DX-SERIES

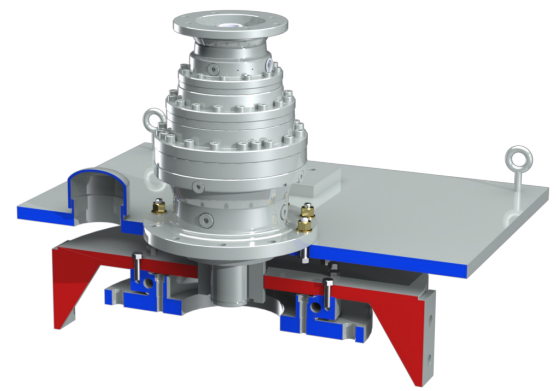
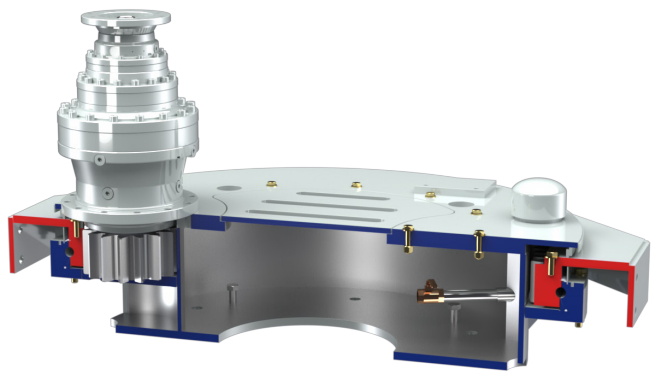

PRIMARY SPEED REDUCER OPTIONS

E-Type

The E-type design uses helical gears for speed reduction and includes alarm and cutoff switches, as well as a shear pin, providing triple protection for the drive unit. This design is employed when the output speed exceeds the limits of the F-type primary speed reducers or when an electro-mechanical drive unit is preferred.



L-Type

The L-type design features a helical gearbox for speed reduction, along with a digital torque meter and a solid-state torque sensor with no moving parts. It incorporates all the features of the E-type reducer and includes a 4-20 mA torque transducer as standard. This design is suitable for all applications.

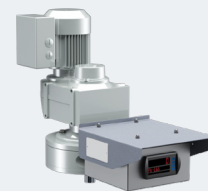

F-Type

The F-type design utilizes a hydraulic pump-motor combination for speed reduction. It features alarm and cutoff switches, as well as hydraulic relief, to provide triple protection for the drive unit. The design is positive torque-limiting and will operate under stalled and semi-stalled conditions. Optional reversing rotation and variable speed are also available.



H-Type

The H-type design incorporates all the features of the F-type primary speed reducer and uses a stand-alone industrial hydraulic power unit. This design is suitable for higher horsepower and multiple pinion drive applications.

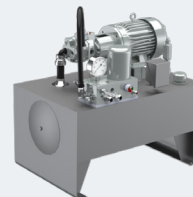

Primary Speed Reducer Option Comparison

Features	E-Type	L-Type	F-Type	H-Type
Drive Train	Helical Gearing	Helical Gearing	Hydraulic	Hydraulic
Display	6" Analog Gauge	6 Digit LED	6" Analog Gauge	4" Analog Gauge
Display Unit	Ft-lbs or N-m	Ft-lbs or N-m	Ft-lbs or N-m	PSI or Pa
Inaccuracy	<5%	<3%	<10%	<10%
Alarm Switch	Standard	Standard	Standard	Standard
Cutoff Switch	Standard	Standard	Standard	Standard
4-20 mA Signal	Adder	Standard	Adder	Adder
Overload Protection	Shear-pin	Shear-pin	Relief valve	Relief valve
HP Limitation	≤3 hp	No limit	≤5 hp	>3 hp
Noise Level	< 70 dB	< 70 dB	<78 dB	<80 dB
Bi-Directional	No	Standard	Optional	Standard
Efficiency	0.94	0.94	0.74	0.74
Variable Speed	Optional	Optional	Optional	Standard
Maintenance Interval	5 Years	5 Years	1 Year	1 Year

LIFT MECHANISM OPTIONS

The lift mechanism is fully contained within the drive unit and can raise and lower the rakes up to 24 inches (600 millimeters) by raising the lift shaft into the drive unit. The lift mechanism does not rotate, so there are no rotary electrical slip rings to maintain. The lift option is offered with manual or powered operation. The powered lift mechanism provides positive lift force control to prevent damage to the rakes or the screw jack.

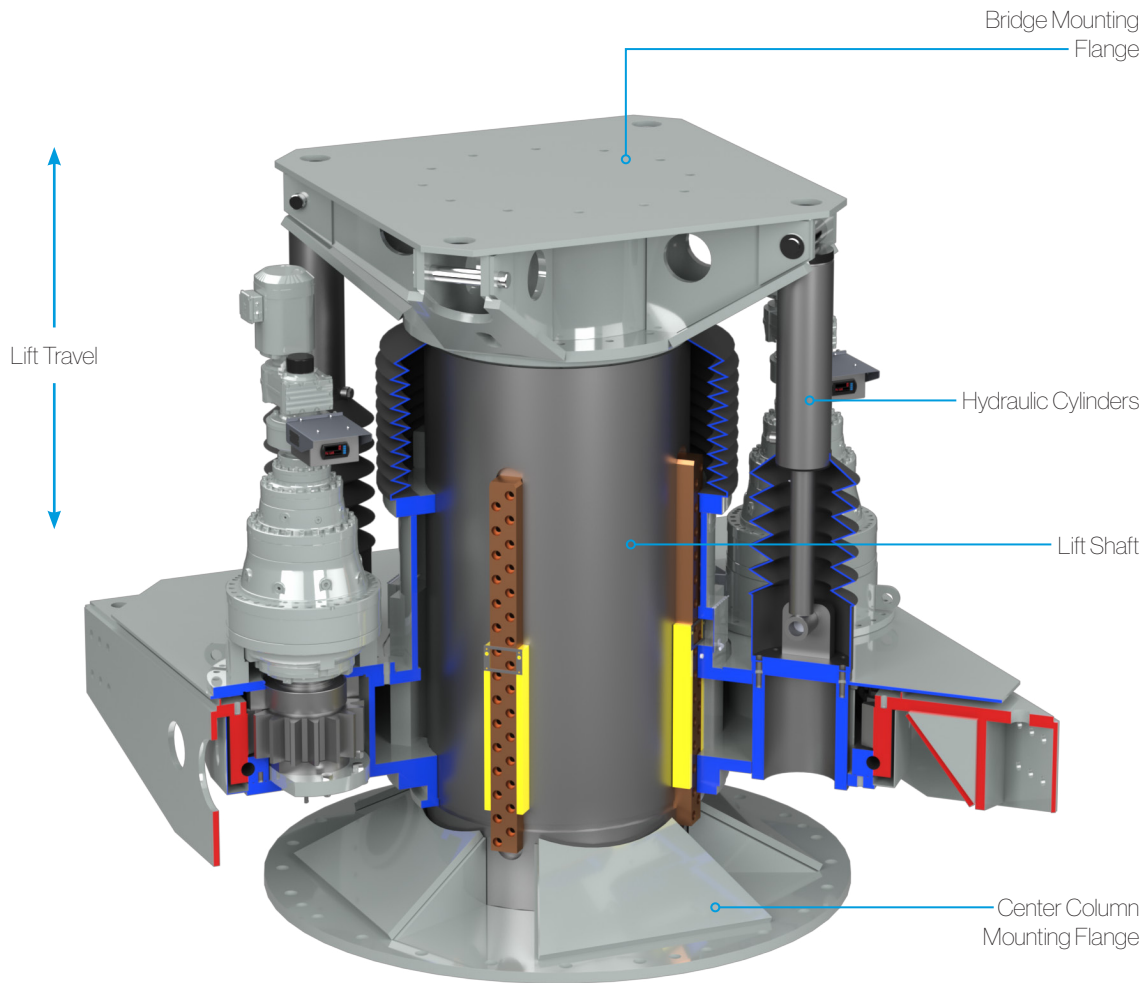

ORDERING INFORMATION

Contact DBS or a DBS representative for assistance in deciding your equipment requirements.

DBS MANUFACTURING

dbsmfg.com/contact

404.768.2131

sales@dbsmfg.com

Pier-Mounted Drive Unit Model Number

Series	Rake Gear Pitch Diameter (Inches)	Secondary Speed Reducer	Primary Speed Reducer	Number of Pinions	Lift Option	Lift Capacity (Tons)	Lift Travel (Inches)	Lift Actuator Option
D	X for no final gear-bearing	A	E F H L	(N/A)	(N/A)	(N/A)	(N/A)	(N/A)
	30	B		1 (omit)	L	Consult Factory	Consult Factory	Consult Factory
		A						
	42	B		1 (omit)				
		C						
	60	D		1 (omit)				
		E						
		D						
	80	E		2				
		E						
	104	G		3				
		G						
120	H	4						
	H							
				5				

Example:

MODEL D30-AF-L1512F D is for a pier-mounted drive unit; 30 is the size of the final gear pitch diameter in inches; A is the size of the secondary speed reducer; F is primary reducer type; L is for a lift mechanism; 15 is the lift capacity in tons; 12 is the lift travel in inches; F is the type lift actuator type.

FEATURES

DBS pier-mounted drive units come standard with alarm and cutoff switches for enhanced safety, a PDF O&M manual, indicates real torque on E and F-type primary reducers. The L-type reducer includes a digital torque display for precise torque measurement.

DBS also offers a range of optional features, including 4-20 mA torque and lift position transducers, bi-directional operation for L, F, and H-type reducers, loss motion switches, variable speed control, explosion proof switches, and special coatings. Additional options include an oil heater for F and H-type reducers, an oil temperature switch, oil level switch, condensate control unit, and stainless steel construction for enhanced durability.

Visit dbsmfg.com for more information.

DBS[®] MANUFACTURING

- Clarifier & Thickener Drives
- Hyperbolic Mixers
- Low-Speed Surface Aerators
- Rotary Distributor Center Mechanisms

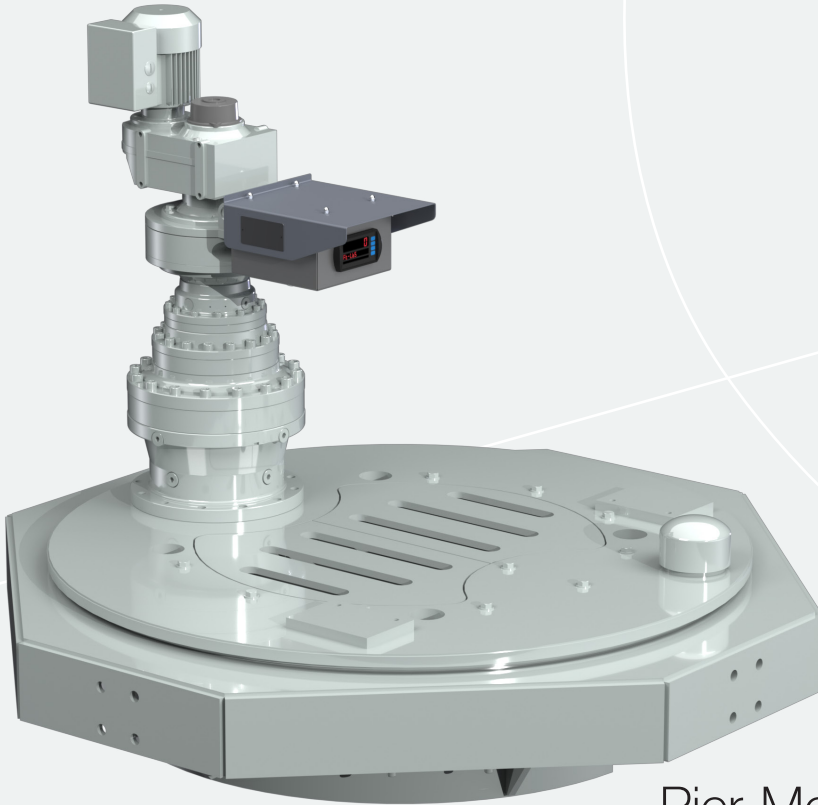

Pier-Mounted Drive Units | D-SERIES
MODEL D42-BL

dbsmfg.com
404.768.2131
sales@dbsmfg.com

45 South Woods Parkway
Atlanta, Georgia 30354